

OILSKIMMERS, INC.[®]

440.237.4600
www.OilSkim.com

10 reasons Oil Skimmers' Model 6-V will solve your outside and in-plant oil contamination problems; save you time and money



If you are confronted with an oil contamination problem that requires prompt, corrective action, we have the answer for you . . . It's our Model 6-V Oil Skimmer. It's versatile, rugged, always dependable, and fully automatic.

No human assistance is required in the skimming operation. All you do is install the 6-V, turn it on and it goes right to work skimming waste oils, mineral and vegetable oils, animal fats, oily froths and other contaminants from water, coolants and cleaning solutions.

The 6-V is not intimidated by heavy debris, nor by gritty and crusted oil conditions that are typically encountered in waste oil skimming operations. The 6-V is engineered to keep on skimming through all sorts of inclement environments, extreme hot or cold temperature conditions, and hard-to-get-at places.

There's much more we would like to tell you about the 6-V. Why not take a few moments and read the "10-Reasons" the 6-V could be the solution to your contamination problems...

1 Our unique method of oil removal

The 6-V utilizes a unique floating tube system. The closed loop tube, made of flexible, specially formulated plastic, attracts oil but not water. The 6-V automatic skimmer

continuously draws the oil-covered tube through scrapers and returns the clean tube to the water surface to gather more oil.

The collector tube, which is sized to your application, snakes over and around floating debris to reach the contaminant. The flexible tube flops so that it breaks through crusted oil or grease and makes these contaminants adhere to the outer surface. The tube will extend as far as 16 feet from shore-line or pit edge when the 6-V is equipped with our balanced boom system.



2 Operates 'round the clock

If you want it to, the 6-V will operate unattended 24 hours a day, seven days a week. And as long and hard as it toils, it never loses its place.

The 6-V has high pickup capacity . . . Light oils can be removed at 240 gallons per day (GPD). Medium oil 600 GPD. Heavy oils 1,440 GPD. The higher the viscosity of the contaminants, the faster 6-V does its job.

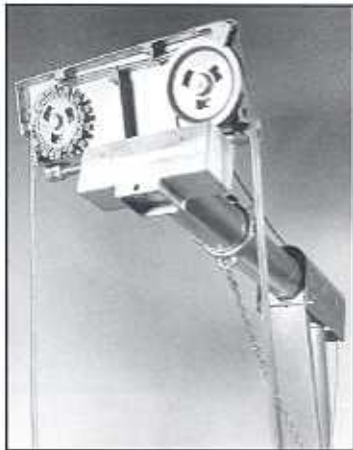

3 Long lasting/low maintenance

The 6-V offers you exceptionally low maintenance. For example, the external parts which contact the grit-laden oil on the collector tube are space-age, high-abrasion-resistant ceramic. These include the drive wheel, scrapers and pressure blocks. Other internal components, such as gears, and bearings, are of high-strength steel and bronze.

The gearing is engineered to eliminate a big strain when in use, and thus requires minimal power demands. And you don't have to be a graduate engineer to service the unit. The simple design not only eliminates frequent maintenance, but makes whatever maintenance you have to perform a one-two-three procedure.

4 A variety of pre-fab mount systems to meet your specific needs



The 6-V's versatility and flexibility are further enhanced by Oil Skimmers' own prefabricated mount systems. The appropriate system can be specified to your operation's requirements. You can choose from a cantilever boom, balanced boom, or angle-frame mount. Each mount system has its own advantages:



- The cantilever boom eliminates the need for costly bridging and foundations; it can easily be serviced from dry land.



- The balanced boom swivels and moves up and down; it is ideal where an extra-long reach is necessary (up to 16 feet from shoreline) and it can even be mounted on a tank trailer where portability is desired.

- The angle-frame is ideal where reach is not necessary; it is suited for "tight spaces."

5 Non-clogging, long-lasting components

The 6-V does not suffer from the clogging and parts maintenance problems often encountered with other types of skimming systems. It works around the debris that is present, always going after the oil you wish to remove.

The 6-V has no tail pulleys or idler wheels to be hooked up below the surface of the pond, pit, or ditch being skimmed. Thus, installation, as well as continuous operation, does not require disagreeable underwater maintenance work. Nor does it require frequent replacement of the collecting device, which, in the 6-V's case, is the highly durable sealed-end plastic tube. The tube is capable of withstanding temperatures of up to 200° F., and it will not fracture in freezing conditions.

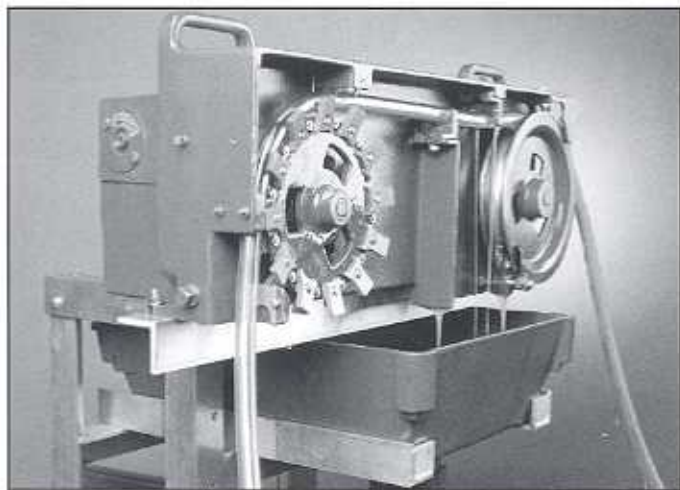

Moreover, Oil Skimmers can outfit the 6-V mechanism with heating elements to keep the oil moving in the coldest weather. For applications where there is exposure to high acidity or other harsh external environments, Oil Skimmers can treat all external metal parts with a special coating for added protection.

6 Manufactured by a reliable company with years of experience

Our skimmers are engineered to have an operational life of at least 15 to 20 years. They are the only products

produced by Oil Skimmers, Inc., the leader in the automatic oil skimming field.

Over the past four decades, we have installed thousands of units throughout the world. Our products are being used by large and small companies in a variety of fields . . . steel and aluminum mills, large manufacturing operations and other heavy industrial producers; food, chemical and oil

processors; the rail, air and trucking service industries. In short, our 6-V skimmers are useful in combatting almost any outside or in-plant oil contamination problem imaginable.

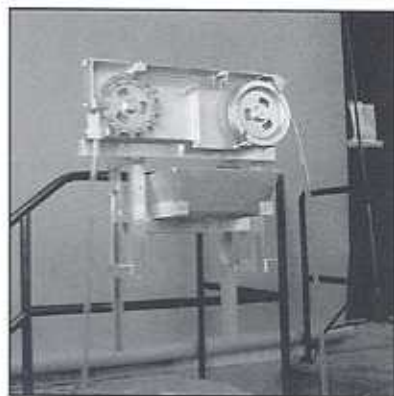

7 On-location survey, counsel

Oil Skimmers will provide a complete on-location survey of your operation's skimming needs, without obligation. And, we will be happy to provide you with our engineering manual on oil spill control, which contains bulletins on all phases of wastewater/oil separation applications, techniques and guidelines.

8 Worldwide dealer/rep/service organization

Our worldwide dealer and representative network affords you quick service and full satisfaction. Our dealers and representatives are experts on all phases of oil/water separation projects, having been involved in countless plant applications.

9 Complete inventory of skimmer equipment accessories, replacement parts

Oil Skimmers prides itself on high-quality products and outstanding service. Thus, we have developed an excellent inventory system, which ensures that orders for new equipment, prefabricated mounts, accessories, and all replacement components are readily available off-the-shelf.

10 Significant cost savings and energy benefits

You will be surprised at how quickly the 6-V can pay for itself . . . It offers you savings through reduced labor, eliminated water or liquid contamination, and less need to use treatment chemicals.

The 6-V is also built to save on energy. Oil Skimmers has a variety of low-power-consumption electric motors which can be specified for your particular needs.

Lastly, many of our customers have discovered yet another major advantage to the 6-V: The oil that it skims can often be reclaimed for further use or even sold to salvagers. Thus, Oil Skimmers can help turn your "problem" into a profitable situation in these energy-starved times.

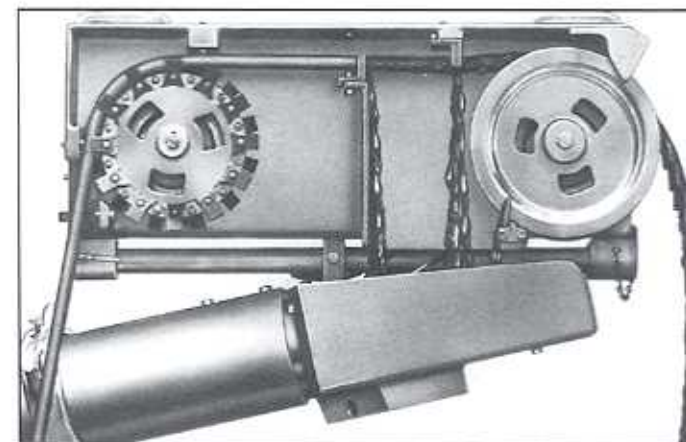

Oil Skimmers' Model 6-V...It does its job while you do yours!

Some further details about our hard-working skimmers.

Oil Skimmers, Inc. has developed a pioneering oil skimming system that has proved its effectiveness and long life in thousands of plant operations throughout the world.

Our skimmer products utilize a flexible floating collector tube that is able to snake over and around debris to reach the oil. The tube floats up and down with varying liquid levels. The tube floats up and down with varying liquid levels. The tube flops so that it breaks up crusted oil or grease, causing these contaminants to adhere to the tube.

The collecting tube can be sized to a variety of lengths to fit your particular applications.

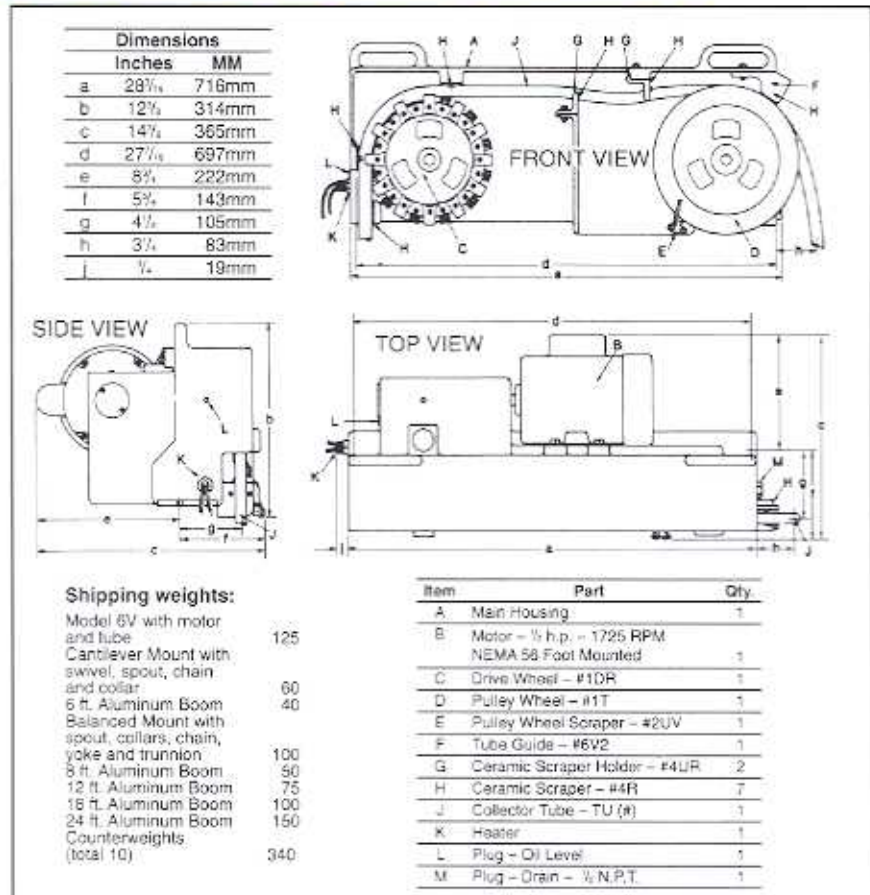

For above-ground tank applications our Model 5-H is your answer.

In addition to the 6-V, Oil Skimmers produces a compact skimmer for the removal of oils, grease and floating sludge from in-plant tanks and vats. Called the 5-H, this unit is perfect for hard-to-get-at places. Like the 6-V, it is fully automatic (no human assistance needed in its operation) and it will work 24 hours a day, 7 days a week. It skims waste oils, mineral and vegetable oil, animal fats, oily froths, and other contaminants from water, coolants and cleaning solutions. Your Oil Skimmers representative will be happy to tell you more about the 5-H.

OILSKIMMERS, INC.[®]

For further information, call or write:

OIL SKIMMERS, INC.
 P.O. Box 33092
 Cleveland, Ohio 44133 USA
 Phone: (440) 237-4600
 Fax: (440) 582-2759
 E-mail: info@OilSkim.com
www.OilSkim.com