

**OILSKIMMERS, INC.**<sup>®</sup>

440.237.4600  
[www.oilskim.com](http://www.oilskim.com)

# 10 reasons Oil Skimmers' Model 5-H will solve your oil contamination problems; save you time and money.



Simple, rugged always dependable.  
That's our Model 5-H.

All you do is turn it on and it goes right to work skimming waste oils, mineral and vegetable oils, animal fats, oil froths, and other contaminants from water, coolants and cleaning solutions.

It keeps on working until the job is done, while you perform other tasks. Model 5-H is one worker that always likes to work alone. But there's a whole lot more to the advantages of the 5-H...Here are 10 you ought to know about.

## 1 Our unique method of oil removal.

The 5-H utilizes a unique floating tube system. The closed loop tube, made of a flexible, specially formulated plastic, attracts oil but not water. The 5-H's automatic skimmer continuously draws the oil-covered tube through scrapers and returns the clean tube to the water surface to gather more oil.

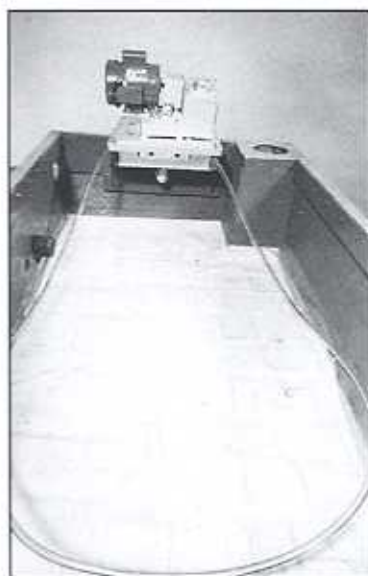

## 2 Operates 'round the clock.

The 5-H likes to work hard. In fact, if you want it to, it will operate unattended 24 hours a day, seven days a week. As long and hard as it works, it never loses its pace.

The 5-H has high pickup capacity...Light oils can be removed at 240 gallons per day. Medium oils at 600 GPD. Heavy oils 1,440 GPD. The higher the viscosity of the contaminant, the faster the 5-H works.

## 3 Picks up oil ...not water and other liquids you wish to keep.

Our collector tube picks up only the oil. Water and other liquids which you wish to retain are not carried off in the process.

Decanters may be added where solution carry-over would be a problem due to frothy emulsions or very small amounts of free oil present. The decanter returns the solution to the process tank and sends just the oil to oil storage.



## 4 Long lasting/low maintenance.

The 5-H offers you exceptionally low maintenance. For example, the external parts which contact the grit-laden oil on the collector tube are special high-abrasion-resistant ceramic. These include the drive wheel, scrapers and pressure blocks.

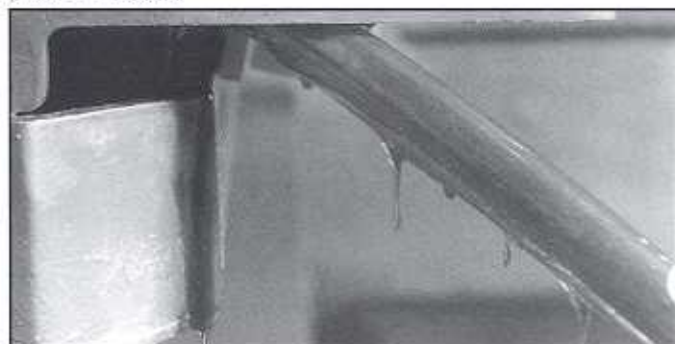

Other internal components, such as gears and bearings, are of high-strength steel and bronze.

The gearing is engineered to eliminate a stress when in use, and thus requires minimal power demands.

And you don't have to be a graduate engineer to service the unit. The simple design not only eliminates frequent maintenance, but makes whatever maintenance you have to perform a one-two-three procedure.

For applications where there is exposure to high acidity or other harsh external environment. Oil Skimmers can treat all external metal parts with an epoxy coating for added protection.

## 5 The perfect solution for tight, hard-to-reach spaces.

The Model 5-H is compactly designed and thus is particularly suited for use in limited space situations and congested plant areas. It can be installed on open or closed tanks.

Typical applications include above-floor, open, and closed tanks used in waste treatment systems, parts washers, and coolant systems.

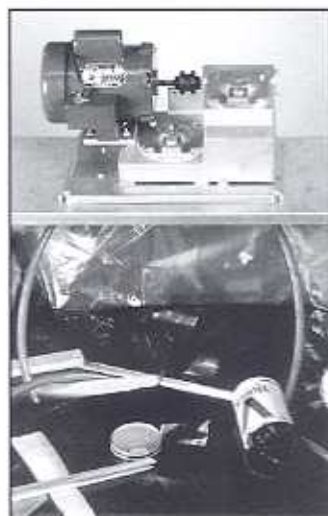

## 6 Pre-fab mount equipment is easy-to-install.

Our skimmer mounts are noted for the ease with which they can be installed. There are no tail pulleys or idler wheels to be hooked up below the surface of the liquid being skimmed. Thus, installation is completed with virtually no "dirty work."

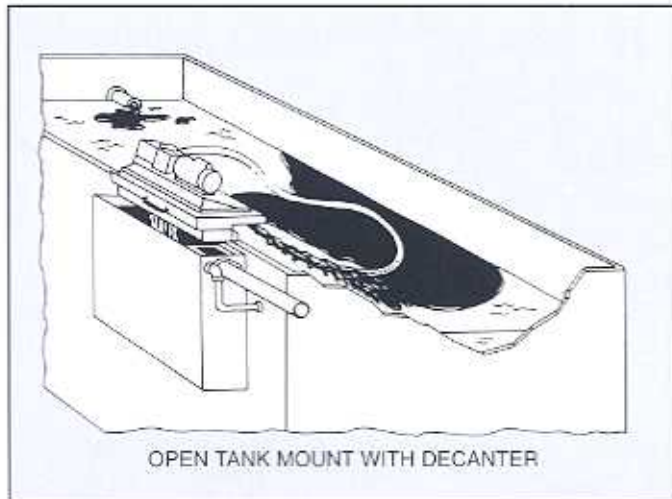

Mounts are available for open and closed tanks, as well as side tank applications. Our mounts eliminate the need for high-cost structural frames often required with competitive skimming devices. They can be made of aluminum, carbon or stainless steel.



## 7 Portable, versatile unit.

The 5-H weighs just 65 pounds and thus can be moved easily from one location to another.

The 5-H can be used in either hot or cold applications. The flexible collector tube is of a composition that will not break under freezing conditions, nor will it succumb in especially hot applications (up to 200° F.).

## 8 Manufactured by a reliable company with years of experience.

Skimming equipment is the only product produced by Oil Skimmers, Inc., the leader in the automatic oil skimming field over the past two decades.

We have installed thousands of units throughout the U.S. and many other countries.

Our products are being used by large and small companies in a variety of fields...steel and aluminum mills, metal machining and manufacturing operations, and other heavy industrial producers, food, chemical, and oil processors; and rail, airline and trucking service industries. In short, our 5-H skimmers are useful in almost any oil contamination situation.

## 9 On-location survey, counsel.

Oil Skimmers will provide a complete on-location survey of your operation's skimming needs, without obligation. And, we will be happy to provide you with our engineering manual on oil spill control, which contains bulletins on all phases of water/oil separation projects, techniques and guidelines.

Our dealers and representatives have been involved in oil skimming projects in countless plant applications throughout the world.

We maintain a complete inventory of equipment and accessories to ensure that your orders are filled properly.

## 10 Significant cost savings and energy benefits.

The 5-H typically pays for itself in a very short time. It offers you savings through reduced labor, reduced liquid contamination and less need to use treatment chemicals. The 5-H has been engineered to have an operational life of over 30 years.

Moreover, the 5-H is built to save on energy. Oil Skimmers has a variety of low-power-consumption electric motors which can be specified for your particular needs.

And, lastly, many of our customers have discovered yet another major advantage to our skimmer: The oil it skims can often be reclaimed for further use or even sold to salvagers. Thus, Oil Skimmers can help turn your "problem" into a profitable situation in these energy-starved times.

**Oil Skimmers' Model 5-H...It does its job while you do yours!**

## Some further details about our hard-working skimmers.

Oil Skimmers, Inc. has developed a pioneering oil skimmer system that has proven its effectiveness and long life in thousands of plant operations throughout the world.

Our skimmer products utilize a flexible floating collector tube that is able to snake over and around debris to reach the oil. The tube floats up and down with varying liquid levels. The tube flops so that it breaks up crusted oil or grease, causing these contaminants to adhere to the tube.

The collector tube can be sized to a variety of lengths to fit your particular applications.

ITEM	DESCRIPTION	QTY
1	MODEL #5H	1
2	MOUNTING PAN ASSEMBLY	1
3	5/16 -18 X 1 1/4 HEX BOLT (FL & LK WASHER)	4
4	3/8-16 HEX HD BOLT WITH WASHER	2
5	COLLECTOR TUBE #5	1
6	CUSTOMER TANK	
7	2" SCH 40 PIPE (FURNISHED BY CUSTOMER)	
8	SIDE PLATE	2
9	HANDLE	1

THE MODEL 5H AND MODEL 6V ARE COVERED BY VARIOUS UNITED STATES AND FOREIGN PATENTS.

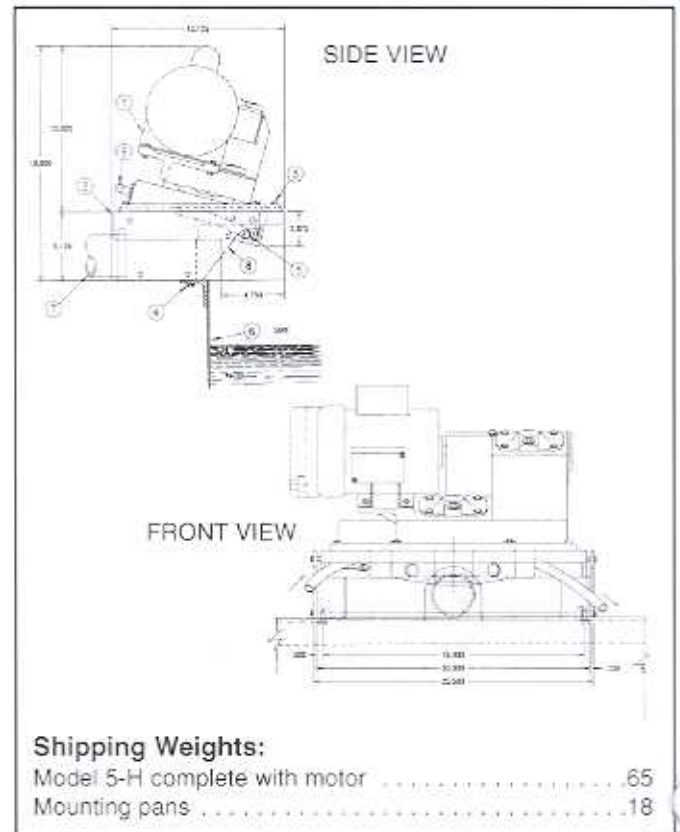

### For bigger jobs, our Model 6-V is your answer.

In addition to the 5-H, Oil Skimmers produces a larger skimmer for the removal of oil from settling ponds, steel mill scale pits, below-floor sumps, and central coolant systems. The larger unit is called the 6-V (see adjoining photo) and is available with three different easy-to-install mount systems — balanced boom, cantilever boom, and angle-frame mount. Your Oil Skimmers representative will be happy to tell you more about the 6-V.



© Copyright 1982 by Oil Skimmers, Inc.  
 ® Registered trademarks of Oil Skimmers, Inc.

For further information, call or write:

**OIL SKIMMERS, INC.**  
 P.O. Box 33092  
 Cleveland, Ohio 44133  
 Phone: (440) 237-4600  
 Fax: (440) 582-2759  
 E-mail: [info@oilskim.com](mailto:info@oilskim.com)  
[www.oilskim.com](http://www.oilskim.com)